



# **INSTRUCTION MANUAL & PARTS BREAKDOWN**

# INSTRUCTION MANUAL

## Table of Contents

Description	2
Safety Guidelines	2
General Safety Information	2-4
Preparation	5-6
Spraying Instructions	6
Cleanup	7-10
Storage	11
Troubleshooting	12-13
Warranty	14
Parts Breakdown	15

## Description

Airless paint sprayers are capable of spraying a wide variety of latex, oil based, and water based paints, as well as stains, preservatives and other non-abrasive finishes.

These sprayers are powerful and versatile enough to be used with a variety of accessories to make them more efficient.

NOTE: Guns pictured in illustrations may be different to the one included with your unit.

## Safety Guidelines

This manual contains information that is very important to know and understand. This information is provided for your SAFETY and to PREVENT EQUIPMENT PROBLEMS. To help recognize this information, observe the following symbols.

### ⚠ DANGER

Danger indicates an imminently hazardous situation which, if not avoided, will result in death or serious injury.

### ⚠ WARNING

Warning indicates a potentially hazardous situation which, if not avoided, could result in death or serious injury.

### ⚠ CAUTION

Caution indicates a potentially hazardous situation which, if not avoided, may result in minor or moderate injury.

## Unpacking

After unpacking the unit, inspect carefully for any damage that may have occurred during transit. Make sure to tighten fittings, bolts, etc. before using the unit.

### ⚠ WARNING

Do not operate a damaged unit, as it may result in a malfunction which can cause injury and/or property damage.

## General Safety

Read all manuals included with this product carefully. Be thoroughly familiar with the controls and the proper use of the equipment.

Always wear a mask or respirator and eye protection when painting.

Keep visitors away and NEVER allow children or pets in the work area.

## Application Chart

Coating	Can Use	Do Not Use	Tip Size	Spray Pressure
Oil Base Stain	x		.011-.013"	1500+ Psi
Wood Sealer	x		.011-.013"	1500+ Psi
Concrete Sealer	x		.011-.013"	1500+ Psi
Enamel	x		.011-.013"	2000+ Psi
Varnish	x		.011-.013"	2000+ Psi
Non-Metal-Flake-Aluminum Paint	x		.011-.017"	2000+ Psi
Vinyl Latex Paint	x		.013-.017"	2000+ Psi
Vinyl/Acrylic Latex Paint	x		.013-.017"	2000+ Psi
Acrylic Latex Paint	x		.013-.017"	2000+ Psi
Oil Base Paint	x		.013-.017"	2000+ Psi
Oil and WaterBased Primer	x		.013-.017"	2000+ Psi
V.V/A&ALatex Stain	x		.013"	2000+ Psi
Textured Coatings		x	N/A	
Elastomerics		x	N/A	
Asphalt Coating		x	N/A	
Wood Restorer		x	N/A	
lock Filler		x	N/A	

## General Safety (Continued)

Do not smoke or eat when spraying paint, insecticides or other flammable substances.

Always work in a clean environment. To avoid injury and damage to the work place, do not aim the spray gun at any dust or debris.

When spraying and cleaning, always follow the instructions and safety precautions.

## DANGER



### Electrical Shock Hazard:

- Follow all local electrical and safety codes, as well as the National Electrical Code (NEC) and in the United States, the Occupational Safety and Health Act (OSHA).
- This product requires a grounded 240V, 10Amp circuit.
- If the power receptacles available do not fit this equipment's power plug, then have an appropriate power receptacle installed by a certified electrician.
- Only qualified electricians or service personnel should perform maintenance on the electrical components of this equipment.
- Do not modify any of the electrical components of this equipment.
- Do not use a power cord adapter with this equipment.
- If using an extension cord, use only grounded three wire extension cords that are in good condition.
- Check with a qualified electrician or

## Appropriate Extension Cord Gauge For Given Lengths

Length of Cord	Gauge
25'	14
25-50'	12
50-100'	10

## WARNING

### Skin Injection Hazard:

Use a face mask respirator and protective clothing when spraying. Always spray in well ventilated areas to prevent health and fire hazards. Refer to the Material Safety Data Sheets (MSDS) of spray material for details.



- Never try to stop leaks with any part of your body.
- This system is capable of producing 3000psi. Only use replacement parts that are rated at 3000psi or higher.
- Never spray without tip guard.
- Ensure trigger lock is functioning properly. See Maintenance section for inspection procedures.
- Always engage trigger lock with not spraying.
- Do not remove spray tip while cleaning the pump.
- Never leave equipment pressurized while unattended. Do not clean tip while it is attached to the spray gun. Remove spray tip from the gun to clean the tip guard.
- Ensure all high pressure connections are tight.
- Do not use pliers to tighten or loosen high pressure connections.

## WARNING

Never aim or spray at yourself or anyone else, serious injury could occur.

Before servicing or storage:

1. Turn the prime/Spray Control to the PRIME position.

NOTE: The prime spray valve has two positions.

Prime: Valve turned all the way to the left (Anti-clockwise)

Spray: Valve turned all the way to the right (Clockwise)

2. Turn the pressure control knob to LOW PRESSURE/HYDRAULIC BLEEDING position.

3. Turn power switch to OFF position.

4. With gun pointed in a safe direction, pull the gun trigger, with the trigger lock disengaged.

5. Engage trigger lock.

Simply turning off the pump motor will not relieve pressure from the system. The above procedure MUST be followed.

## WARNING

### Fire or Explosion Hazard:

Do not use solvents with flash points less than 70°F (20°C) to clean this equipment.

## General Safety (Continued)

### **⚠ WARNING**

Do not spray flammable materials in vicinity of open flame or near ignition sources. Motors, electrical equipment and controls can cause electrical arcs that will ignite a flammable gas or vapour. Never store flammable liquids or gas in the unit.

### **⚠ WARNING**

Do not spray acids, corrosive materials, toxic chemicals, fertilizers or pesticides. Using these materials could result in death or serious injury.

- Do not use fuels to clean this equipment.
- Keep spraying area well ventilated and keep doors and windows open.
- Remove all ignition sources (i.e. static electricity, pilot lights, cigarettes, and electrical arcing).
- Airless spraying can cause static electricity. Always ground the pump and spraying surface. Always use a 3-wire grounded extension cord and power receptacle.
- Do not use solvents containing halogenated hydrocarbons.

### **⚠ CAUTION**

Keep hose away from sharp objects. Bursting hoses may cause injury. Examine hoses regularly and replace them if they are damaged.

- Check hoses for weak or worn areas before each use. Make sure that all connections are secure.

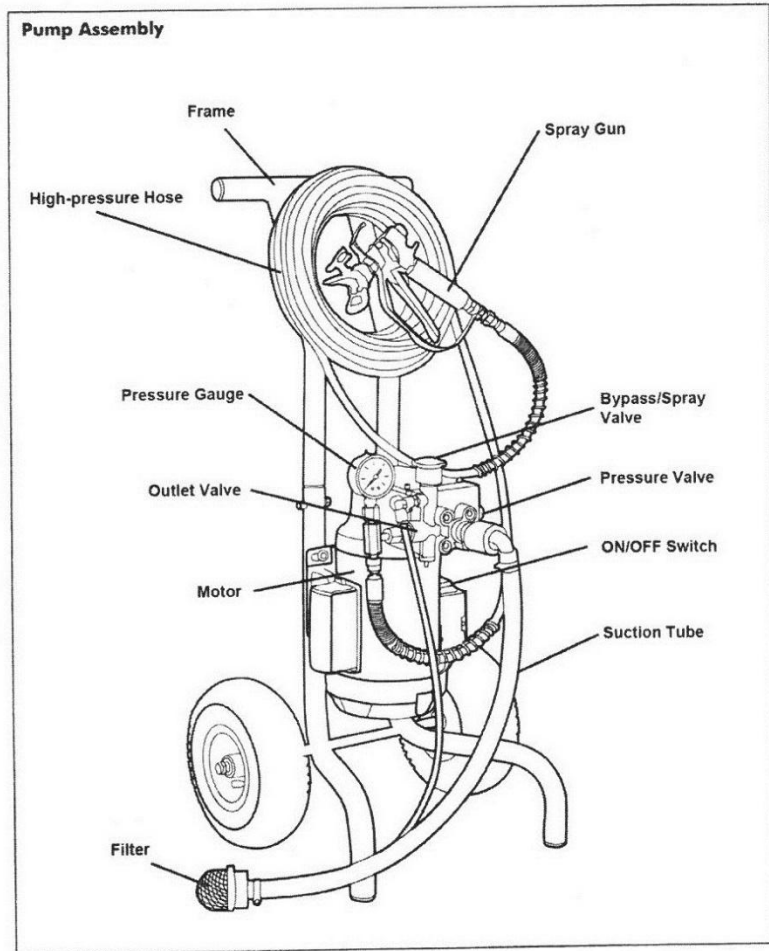

## Preparation

Airless painting systems, unlike most other power tools, require additional care to ensure proper working order. Following these instructions will significantly increase the likelihood of having a positive painting experience.

It is important that the painting equipment is flush tested EACH time a new job is started. Each pump is tested at the factory with a fluid that must be flushed from the system prior to painting. It is also required prior each successive use to flush the storage lubricant from the system. Use the solvent which will be used to clean the equipment. Refer to the paint manufacturer's recommendations for cleaning fluids.

## Preparation (Continued)

1. Remove inlet valve cap and with your smallest finger, push on inlet valve stem to ensure it moves freely. Push outlet prime button three times to ensure outlet valve is moving freely.

2. Turn prime/spray control to the PRIME position.

3. Turn power switch to the ON position.

4. Place bypass tubes in cleaning solvent.

5. Attach suction assembly securely and place it in the cleaning solvent. In a few seconds, cleaning solvent will begin to move up through the tube. Allow the fluid to circulate for one minute to ensure all air has been exhausted from the pump.

6. Turn pressure knob to the HIGH position (completely clockwise)

7. Turn prime/spray control to SPRAY position. Watch for any fluid leaks (See Troubleshooting section if leaks occur).

NOTE: If unit is building up pressure properly, the pump should produce a slight knocking sound, which indicates it has reached its hydraulic relief pressure. The pressure gauge should also read 3000psi.

8. When flushing the system with cleansing fluid (either prior to use with paint or during cleaning process) the spray tip can remain in the CLEAN position.

9. Point spray gun into an empty waste bucket and pull the trigger. To reduce splashing, direct the fluid stream along the inside of the bucket wall and well

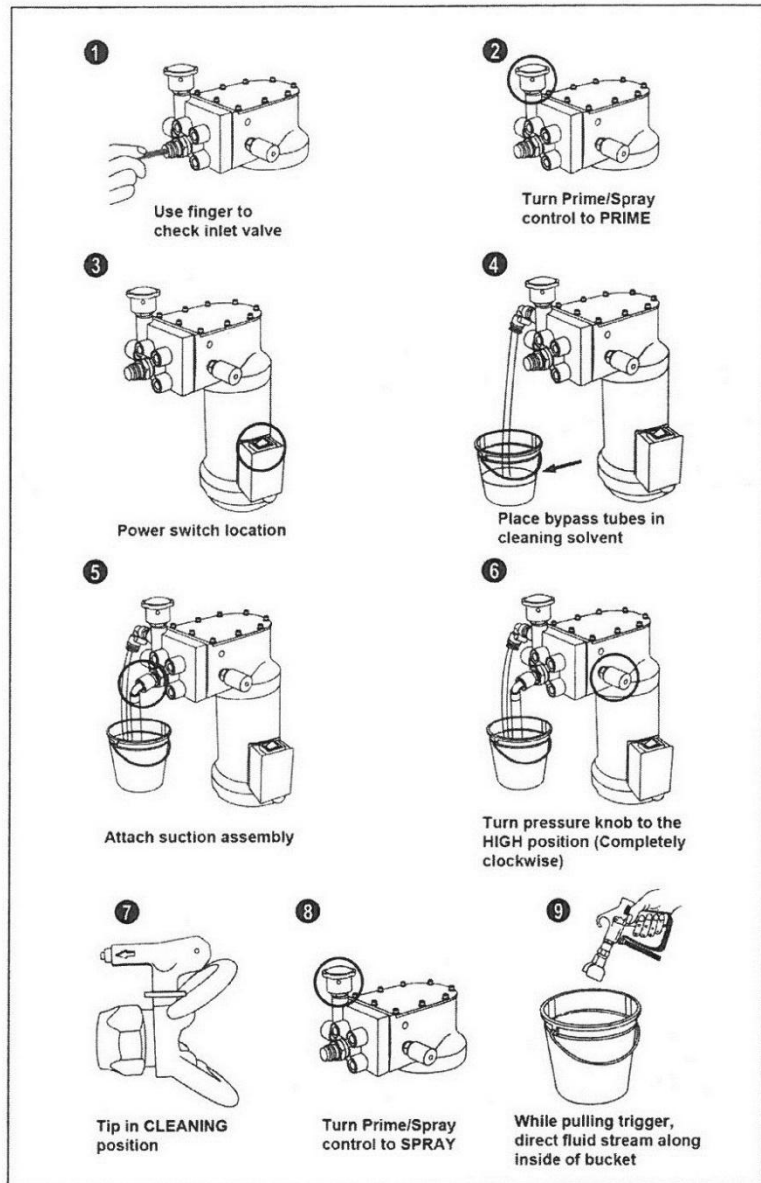

NOTE: The manual refers to "Cleaning Solvent". If you are using water based paint, the cleaning solvent will be water. You must refer to the paint manufacturer's guide for 'Clean up'.

## Preparation (Continued)

10. After completing the flush/testing process, purge the pump of fluid.

11. Repeat the preceding steps using paint instead of cleaning solvent.

NOTE: Strain and thin paint before using. All paint may have particles that will clog filter and spray tips.

Remove any skin which may have developed on the paint due to air exposure. Follow paint manufacturer's recommendations on thinning paint.

12. When pure paint appears from the spray tip, rotate tip to the SPRAY position. The system is now ready for use.

## Spraying Instructions Intermittent Use

If you are spraying and decide to stop for several minutes, lock the spray gun trigger and submerge the tip in a container of suitable solvent. This will prevent paint from hardening in the spray opening and clogging tip. Be sure to release the pressure by turning the bypass knob to prime and switch off the pump.

## Clearing Clogs Reversible Tip

1. Rotate the tip to the clean position. Point the gun in a safe direction and spray. This should clear the tip of any blockage.

2. Rotate the tip back to the spray position and continue spraying.

3. If the clogging continues, clean or replace the gun filter and see the Preparation section of this manual for instructions on straining and thinning paint.

NOTE: The equipment can be damaged if a needle or sharp object is used to clean the tip. Tungsten carbide is brittle and can be chipped.

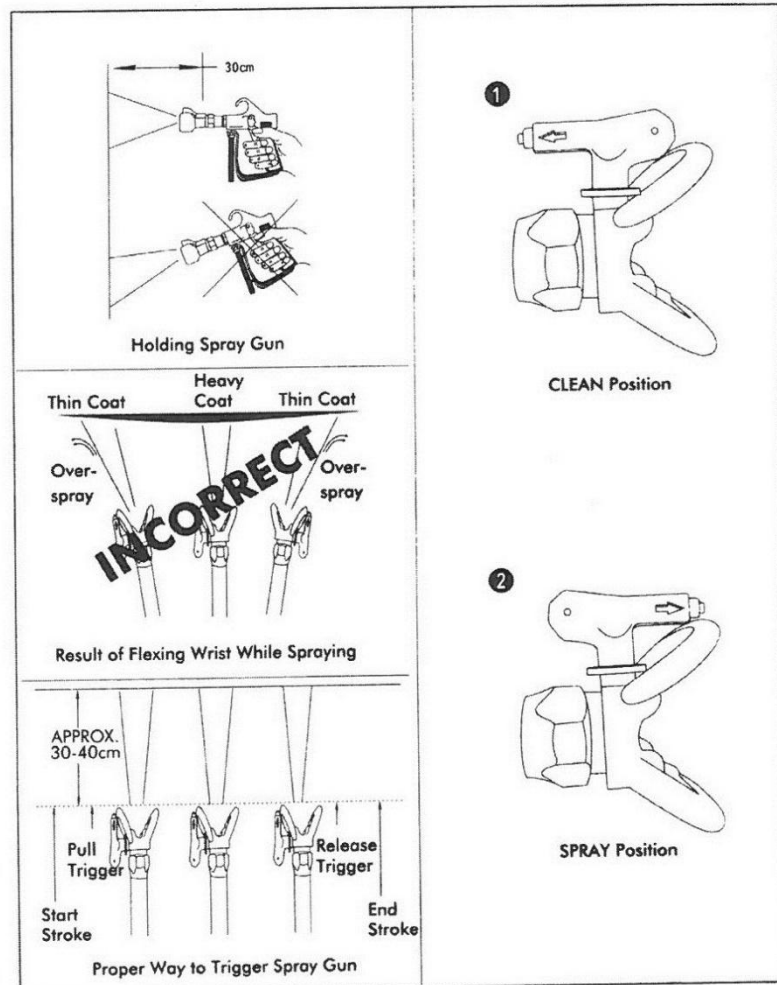

## Cleanup for Overnight Storage

Cleaning and maintenance of the pump are the most important steps you can take to ensure proper operation and a long life for your airless paint sprayer. Please follow the cleaning instructions carefully and WEAR ALL NECESSARY SAFETY GEAR.

When reusing the sprayer with the SAME PAINT the next day at the SAME JOB SITE, it is not necessary to flush the paint from the system. However, it is important to keep air from coming into contact with the paint.

## Necessary Tools/Materials

- One (1) bucket
- Solvent
- Plastic wrap

### ⚠ CAUTION

NOTE: Do NOT disconnect any hoses. The high pressure hose may still be pressurized with prime/spray control in the PRIME position. With the gun pointed in a safe direction, pull the gun trigger to relieve any pressure in the hose.

1. Turn prime/spray control to PRIME position.
2. Engage gun trigger lock.
3. Place spray gun in bucket of appropriate solvent. There should be enough solvent to COVER the spray tip. This will prevent paint from drying or clogging the tip.
4. Leave suction and bypass tubes in the paint bucket. Make sure ends of the suction and bypass tubes are BELOW the surface of the paint in the bucket.
5. Cover bucket and tubes with plastic wrap or a damp towel to prevent film forming on paint. Or, if using a water based paint, pour a very thin layer of water over the top of the paint. Stir water into paint the next morning.

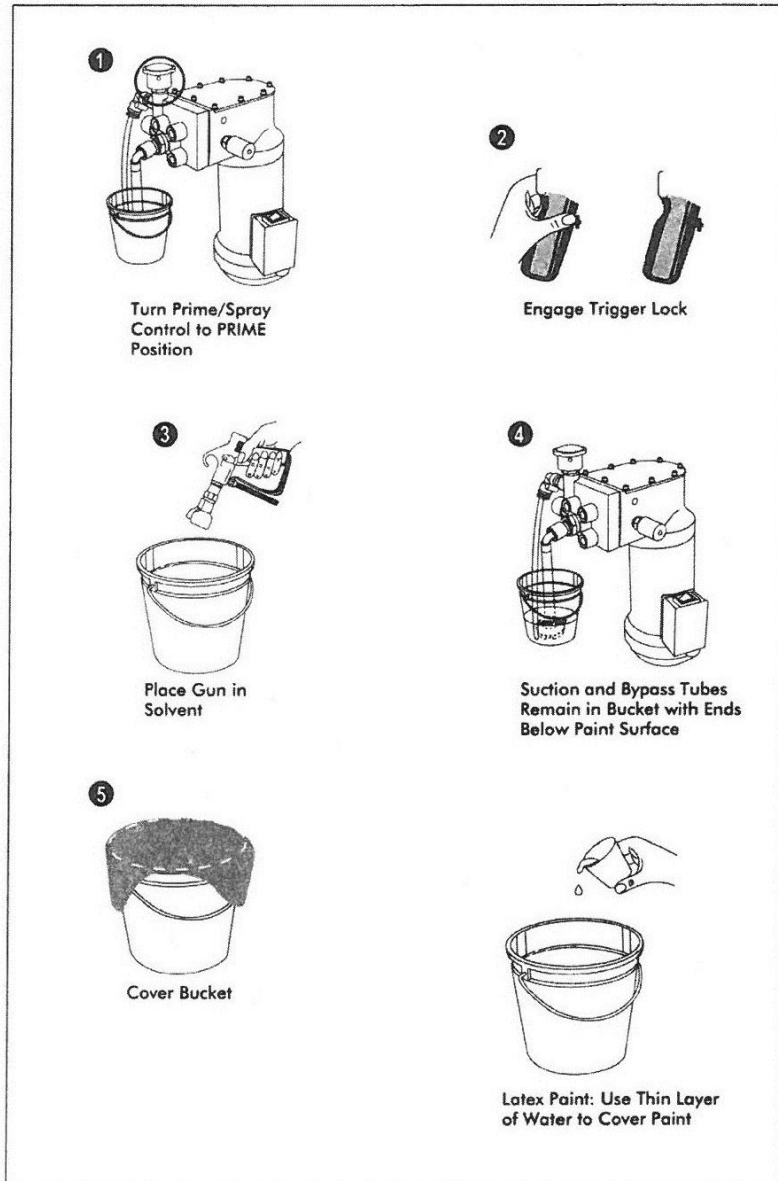

## Cleanup for Changing Paints or Temporary Storage For More Than One Night

### CAUTION

NOTE: Do NOT disconnect any hoses. The high pressure hose may still be pressurized with prime/spray control in the PRIME position. With the gun pointed in a safe direction, pull the gun trigger to relieve any pressure in the hose.

Refer to coating manufacturer for recommended cleaning fluid.

1. Turn prime/spray control to PRIME position.
2. Turn power switch to ON.
3. Turn pressure to HIGH (Completely clockwise).
4. Lift suction assembly above fluid level in bucket.

NOTE: If using a vertical unit, tilt unit back. While holding suction assembly above the paint level, allow pump to run until empty.

5. Immediately place both suction assembly and bypass tube in a bucket containing enough cleaning fluid to cover suction bell by two inches. Allow pump to prime and begin circulating fluid.

6. While fluid is circulating, soak rag in fluid and wipe exterior of suction assembly and bypass tube. Remove suction filter. Wash inside of the suction filter housing with rag removing excess paint buildup. Clean the suction filter thoroughly and screw back onto the suction tube.

## Necessary Tools/Materials

- Wrench (adjustable)
- Rag
- Gloves
- Two (2) buckets
- One (1) gallon of cleaning fluid
- Cleaning brush

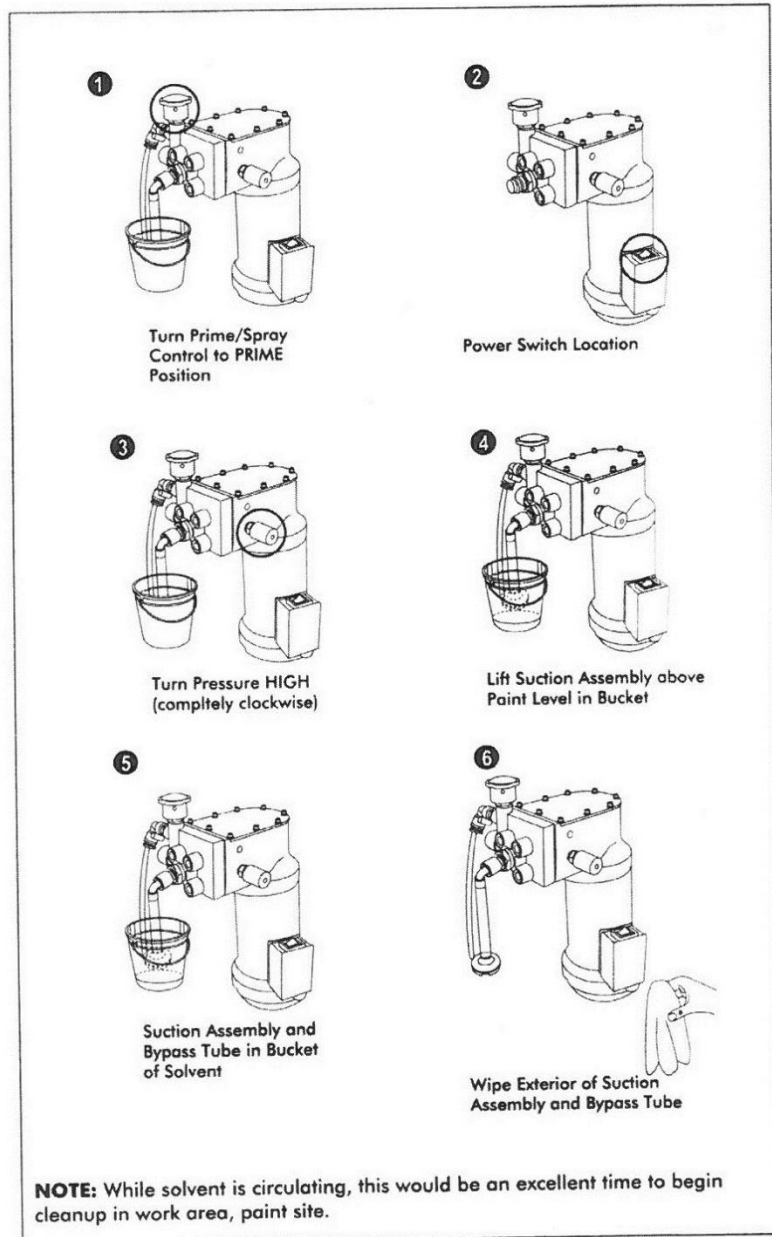



## Cleanup for Changing Paints or Temporary Storage For More Than One Night (Continued)

Allow the solvent to continue circulating for approximately 10 minutes.

7. Turn pressure to HIGH (Completely clockwise).

8. Turn prime/spray control to SPRAY/ROLL position.

9. If a reversible tip is used, rotate spray tip to CLEAN position.

10. Point spray gun into the bucket of paint and pull trigger.

NOTE: To reduce splashing, direct fluid stream along inside of the bucket and above the paint level.

11. As soon as the cleaning fluid flows out of the spray gun, release the trigger.

12. Engage gun trigger lock.

13. Turn prime/spray control to PRIME position.

14. Turn pressure control to HIGH.

15. Lift suction assembly above fluid level in bucket.

NOTE: Allow pump to run until the bucket is empty.

16. Repeat process (1 – 15) with fresh cleaning fluid, to remove contaminated cleaning fluid from initial cleaning.

### Cleaning Hose and Gun

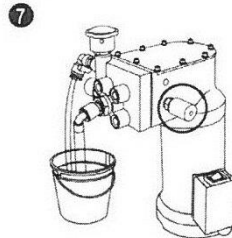

7 Turn Pressure to HIGH (completely clockwise)

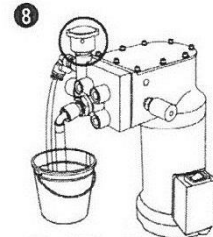

8 Turn Prime/Spray Control to SPRAY (knob is horizontal)



9 If Reversible Tip is Used, Rotate Spray Tip to CLEAN Position

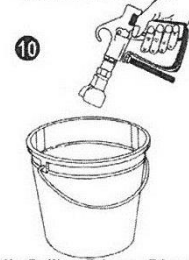

10 While Pulling Trigger Direct Fluid Stream Along Inside of Bucket



11 Release Trigger

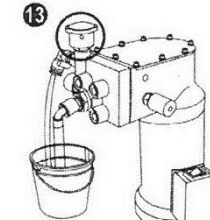

13 PRIME Position



12 Engage Gun Trigger Lock

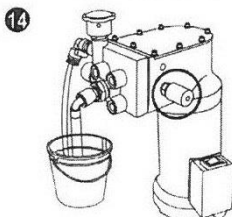

14 HIGH PRESSURE Position

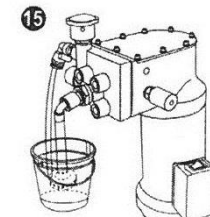

15 Lift Suction Assembly

## Cleanup for Changing Paints or Temporary Storage For More Than One Night (Continued)

17. Make sure prime/spray control is in SPRAY position to reduce dribbling.
18. Turn pressure to LOW (Completely counterclockwise).
19. Turn power switch to OFF position.
20. With gun pointed to safe direction, pull trigger with lock released to relieve any pressure in the hose.
21. Engage gun trigger lock.
22. Clean buckets and dispose of any waste paint and cleaning fluid in an environmentally friendly manner.
23. Clean tip guard with cleaning brush and cleaning fluid.

NOTE: At this point, the pump, hose and spray gun are clean, but still require further preparation for storage of more than one day.

### Finishing Touches/Shutdown

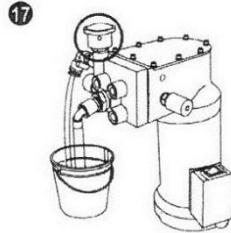

Prime/Spray is in SPRAY position

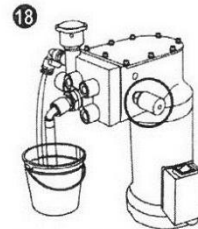

Turn pressure to LOW (Completely counterclockwise)

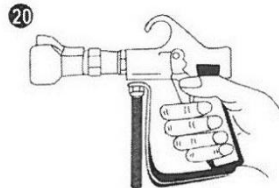

Pull gun trigger with trigger lock released, then engage trigger lock

## Short Term Storage Less Than One Week

### OIL OR WATER BASED PAINT

If the sprayer has been cleaned with mineral spirits, simply wrap the suction filter housing in plastic to keep debris out. No other preparation is necessary.

### WATER-BASED PAINT

1. Prepare the pump saver in a bucket as directed on the container.
2. Place suction assembly into the pump saver.
3. Place end of bypass tube into the waste bucket.
4. With prime/spray control in PRIME position, turn the pressure to HIGH (Completely clockwise).
5. Turn power switch ON. Circulate pump saver through the bypass tube until the bucket of solution is empty.
6. Turn pressure to LOW (Completely counterclockwise).
7. Wrap suction filter housing in plastic to keep debris out.

## LONG TERM More Than One Week

8. Remove high pressure hose and drain. Reassemble high pressure hose to pump.
9. With spray tip attached to spray gun, wrap the tip with plastic to protect it.

## Necessary Tools/Materials

- Pump Protector Solution
- Wrench (adjustable)
- Plastic Wrap

## WEAR ALL NECESSARY SAFETY GEAR

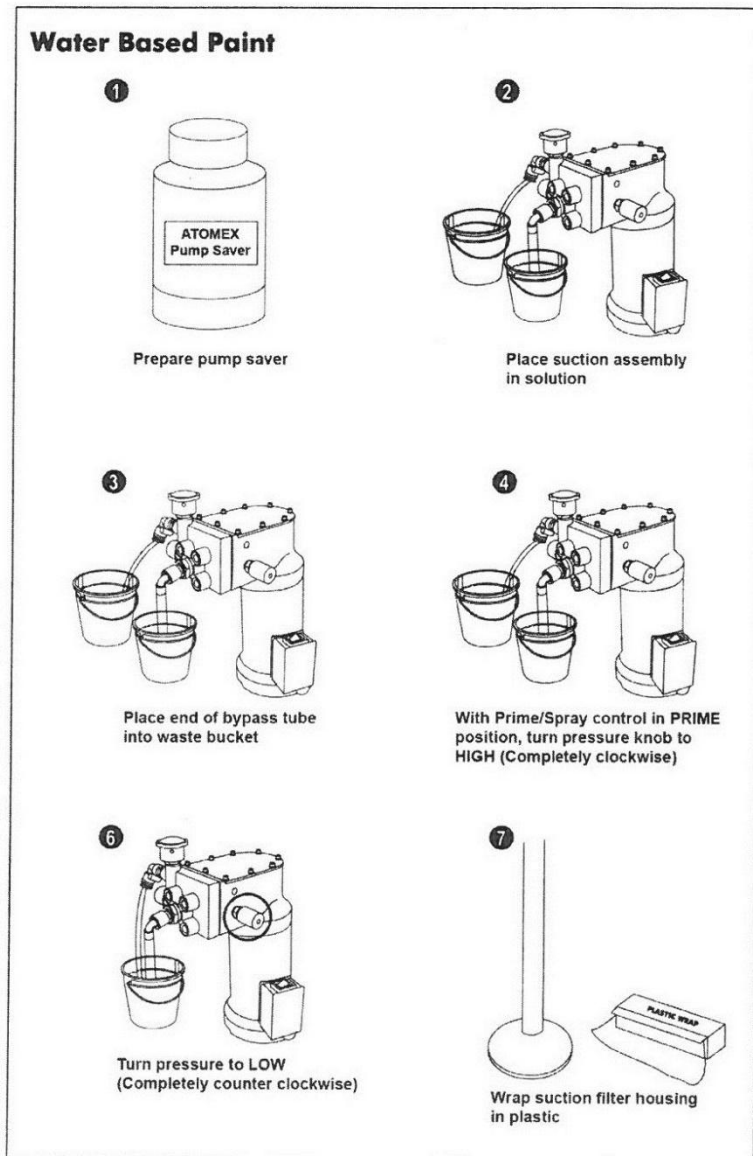

## Troubleshooting Chart

Symptom	Possible Cause(s)	Corrective Action
Motor runs but won't prime material	<ol style="list-style-type: none"> <li>1. Inlet or outlet valve stuck</li> <li>2. Suction tube connection loose or washer worn</li> <li>3. Prime/spray knob in spray position</li> <li>4. Prime/spray valve dirty or worn</li> <li>5. Hydraulic system contains air causing lack of suction and no diaphragm movement</li> <li>6. Suction tube filter clogged</li> <li>7. Inlet or outlet valves dirty or worn</li> <li>8. Material is too thick or not strained properly</li> <li>9. Pressure knob set too low</li> </ol>	<ol style="list-style-type: none"> <li>1. Push the spring inside the inlet valve &amp; push on outlet valve</li> <li>2. Tighten or replace washer</li> <li>3. Turn knob to prime position</li> <li>4. Remove and clean or replace valve (located behind blue knob)</li> <li>5. Rebleed pressure valve. Turn knob to LOW and allow motor to run for a few minutes. Then turn knob to HIGH</li> <li>6. Clean or replace suction tube filter</li> <li>7. Remove and clean or replace inlet and outlet valve</li> <li>8. Thin, mix and strain all material to be sprayed</li> <li>9. Turn knob to HIGH</li> </ol>
Sprayer builds pressure but pressure drops when gun is triggered	<ol style="list-style-type: none"> <li>1. Inlet and/or outlet valves are worn</li> <li>2. Suction tube washer dirty or worn</li> <li>3. Suction tube or suction filter clogged</li> <li>4. Clogged gun filter or worn tip</li> <li>5. Tip is too large for material being sprayed</li> <li>6. Equalizer on suction hose assembly is damaged</li> </ol>	<ol style="list-style-type: none"> <li>1. Remove and replace valves as needed</li> <li>2. Replace suction tube washer</li> <li>3. Replace suction filter</li> <li>4. Replace filter or tip</li> <li>5. Replace with smaller size tip</li> <li>6. Replace suction hose assembly</li> </ol>
Unit primes but will not build pressure	<ol style="list-style-type: none"> <li>1. Dirty or worn inlet valve</li> <li>2. Inlet valve sticking due to material</li> <li>3. Pressure (red knob) not turned up high enough</li> <li>4. Oil level in the hydraulic housing is too low.</li> <li>5. Damaged suction hose washer</li> <li>6. Material is too thick or not properly strained</li> <li>7. Dirty, stuck or worn prime/spray valve causing fluid to come through bypass tube while unit is in spray position</li> </ol>	<ol style="list-style-type: none"> <li>1. Remove and replace valves as needed</li> <li>2. Remove suction hose and pop inlet valve poppet</li> <li>3. Turn knob to higher setting or replace valve if necessary</li> <li>4. Check oil level. If low, fill to 1/4" from top of housing</li> <li>5. Replace suction hose washer</li> <li>6. Thin and/or strain material</li> <li>7. Remove and clean or replace valve</li> </ol>
Gun continues to spray when trigger is released	<ol style="list-style-type: none"> <li>1. Gun valve has paint build up inside gun valve or is dirty</li> <li>2. Gun valve is worn</li> <li>3. Gun trigger is not properly adjusted</li> <li>4. Filter housing is tightened down too much</li> </ol>	<ol style="list-style-type: none"> <li>1. Clean or replace gun valve</li> <li>2. Replace gun valve or replace entire gun</li> <li>3. Adjust trigger by adjusting nut behind trigger. Move nut towards handle if trigger does not move. Tighten nut by turning towards spray tip if trigger moves too much</li> <li>4. Turn filter housing bolts about 1/2 turn counterclockwise</li> </ol>
Sprayer motor doesn't start up or just hums	<ol style="list-style-type: none"> <li>1. Paint system is under pressure or Prime/spray knob in spray position</li> <li>2. Motor thermal overload switch is tripped</li> <li>3. Motor not aligned properly</li> <li>4. Use of extension cord that is too long or too small in gauge</li> <li>5. Blown fuse or tripped circuit breaker</li> </ol>	<ol style="list-style-type: none"> <li>1. Turn blue knob to prime position and pull gun trigger</li> <li>2. Turn unit off. Turn blue knob to PRIME position then unplug cord and allow unit to cool for 20-30 minutes</li> <li>3. Remove fan shroud then loosen the four motor mount screws and retighten in X pattern to 30 in. lbs.</li> <li>4. Plug unit directly into an outlet and extend hose length</li> <li>5. Replace fuse, reset circuit breaker or use 20 amp circuit breaker</li> </ol>
Motor overheats and/or cuts off	<ol style="list-style-type: none"> <li>1. Extension cord is too long or gauge is too small</li> <li>2. Paint overspray is being drawn into motor causing it to overheat</li> <li>3. Material is too thick for paint sprayer to prime</li> <li>4. Sprayer is being used in an area of poor air circulation</li> <li>5. Tripped circuit breaker</li> <li>6. Loose wire or bad shell</li> </ol>	<ol style="list-style-type: none"> <li>1. Get correct gauge size or plug directly into outlet and use more spray hose</li> <li>2. Inside of motor must be cleaned or replace motor</li> <li>3. Thin, mix and strain all materials</li> <li>4. Move unit to an area with good air circulation</li> <li>5. Check receptacles for too much voltage/amperage</li> <li>6. Check wiring in motor or replace motor</li> </ol>

## Troubleshooting Chart

Symptom	Possible Cause(s)	Corrective Action
Oil leaks or oil in paint	<ol style="list-style-type: none"> <li>1. Leaking oil between block and hydraulic housing</li> <li>2. Oil leak coming from motor; bad motor seal</li> <li>3. Deep scratch in the grooves by diaphragm</li> </ol>	<ol style="list-style-type: none"> <li>1. Tighten block bolts in X pattern. If oil is still leaking then remove block and change diaphragm.</li> <li>2. a. Replace unit b. Contact service Center to have motor housing replaced</li> <li>3. Contact Service Center to have hydraulic housing and diaphragm replaced</li> </ol>
Leaking paint form sprayer	<ol style="list-style-type: none"> <li>1. Leaking point between block and hydraulic housing</li> <li>2. Leaking paint from outlet push-pull</li> <li>3. Leaking paint from suction hose connection</li> <li>4. Leaking point around outlet valve assembly; O-ring on outlet valve is damaged</li> <li>5. Leaking paint from hose adapter</li> </ol>	<ol style="list-style-type: none"> <li>1. Tighten block bolts in X pattern or replace block</li> <li>2. Tighten or replace; if still leaking, then replace block</li> <li>3. Remove suction hose and check for damaged washer and damaged threads on connector and inlet. Replace parts as necessary</li> <li>4. Remove and replace outlet valve</li> <li>5. a. Tighten hose adapter b. Check for damaged thread on connector. Replace if necessary</li> </ol>
Unit primes and builds pressure but will not spray	<ol style="list-style-type: none"> <li>1. Prime/spray knob is not in spray position</li> <li>2. Clogged spray tip</li> <li>3. Clogged gun filter</li> <li>4. Tip is damaged or worn</li> <li>5. Spray tip in clean position</li> <li>6. Paint requires thinning</li> </ol>	<ol style="list-style-type: none"> <li>1. Turn blue knob to spray/roll position</li> <li>2. Turn spray tip to clean position, squeeze trigger then turn back to spray position</li> <li>3. Replace gun filter, be sure filter housing is clear of debris</li> <li>4. Replace tip</li> <li>5. Turn spray tip to the spray position</li> <li>6. Follow paint manufacturers thinning recommendations</li> </ol>
Poor spray pattern-tails, bursts of material, splatches in pattern	<ol style="list-style-type: none"> <li>1. Material too thick or not strained</li> <li>2. Spray tip dirty or worn, defective tip</li> <li>3. Dirty or worn inlet or outlet valve</li> <li>4. Pressure is adjusted too low for material being sprayed</li> <li>5. Clogged suction filter</li> <li>6. Clogged gun filter</li> <li>7. Tip is large for material being sprayed</li> </ol>	<ol style="list-style-type: none"> <li>1. Thin, mix and strain all material</li> <li>2. Clean or replace spray tip</li> <li>3. Remove and clean or replace inlet and/or outlet valve</li> <li>4. Turn pressure (red knob) clockwise to increase pressure to gun</li> <li>5. Clean or replace suction filter</li> <li>6. a. Remove gun filter b. Check for debris in filter housing c. If debris is found, force water through gun while filter is still removed d. Replace filter</li> <li>7. Replace with smaller tip size</li> </ol>

## Warranty and Limitation of Liability

The factory warranty is valid for 12 months beginning on the date of sale as indicated on the sales invoice. The warranty includes and is limited to elimination of a defect, proven to have been caused by faulty production materials or errors during assembly.

The defect may be rectified by repair or replacement of the defective part at our discretion.

Use of this machine, start-up or do it yourself assembly/disassembly or repairs which are not listed in our operating instructions are not covered under our warranty.

Parts subject to normal wear and tear through normal use of this machine are not covered by the warranty.

The warranty does not cover commercial or contractor use for DIY machines.

We reserve the right to make judgments on warranty obligations.

The warranty is void if any maintenance and service outside the maintenance detailed in this operators manual are carried out by non authorized service personnel.

Transport related damage, maintenance work and damage and malfunctions caused by improper maintenance work are not covered by the warranty.

All warranty claims must have proof of purchase provided, with submitting the original receipt of purchase.

We are not liable for any personal, material or consequential damages, including any resulting from use of the unit other than as intended in the operating instructions, start-up or repair in a manner other than described in our operating instructions or repairs performed by non authorised personnel.

Repairs going above and beyond those dealt with in these operating instructions are reserved for our authorised service outlets.

In the case of any warranty claim please refer in the first instance to your point of sale.

# Spare Parts

## Index

<b>Contents</b>	<b>Page</b>
Pump Head Assembly.....	16
Main Assembly.....	17
Diaphragm Assembly.....	18
Suction Hose Assembly.....	19
Pressure Gauge Assembly.....	19
X-360 Gun Assembly .....	20

**For all technical enquires & spare parts ordering please contact**

# Pump Head Assembly

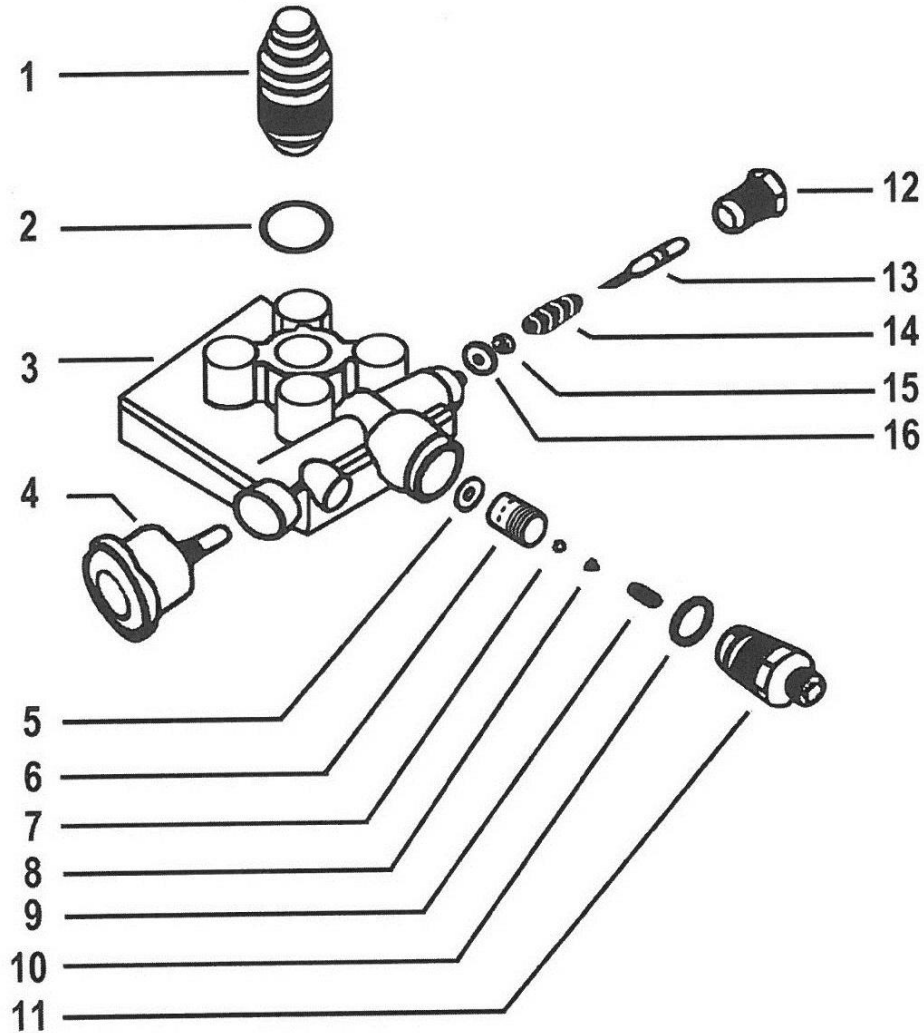

## Parts List

Item	Description	Qty	Part No.	Item	Description	Qty	Part No.
1	Suction Valve.....	1	AX/GM-20001	9	Outlet Spring.....	1	AX/GM-20009
2	Seal.....	1	AX/GM-20002	10	O Ring.....	1	AX/GM-20010
3	Pump Head.....	1	AX/GM-20003	11	Outlet Fitting.....	1	AX/GM-20011
4	Prime/Spray Valve.....	1	AX/GM-20004	12	Pusher Body.....	1	AX/GM-20012
5	Outlet Valve Seat .....	1	AX/GM-20005	13	Pusher Stem.....	1	AX/GM-20013
6	Ball Seal.....	1	AX/GM-20006	14	Pusher Spring.....	1	AX/GM-20014
7	Ball.....	1	AX/GM-20007	15	Seal.....	1	AX/GM-20015
8	Ball Guide.....	1	AX/GM-20008	16	Pusher Washer.....	1	AX/GM-20016

Note: Item 3 can be used as a complete assembly (AX/GM-20003A) - See page 18



## Main Assembly

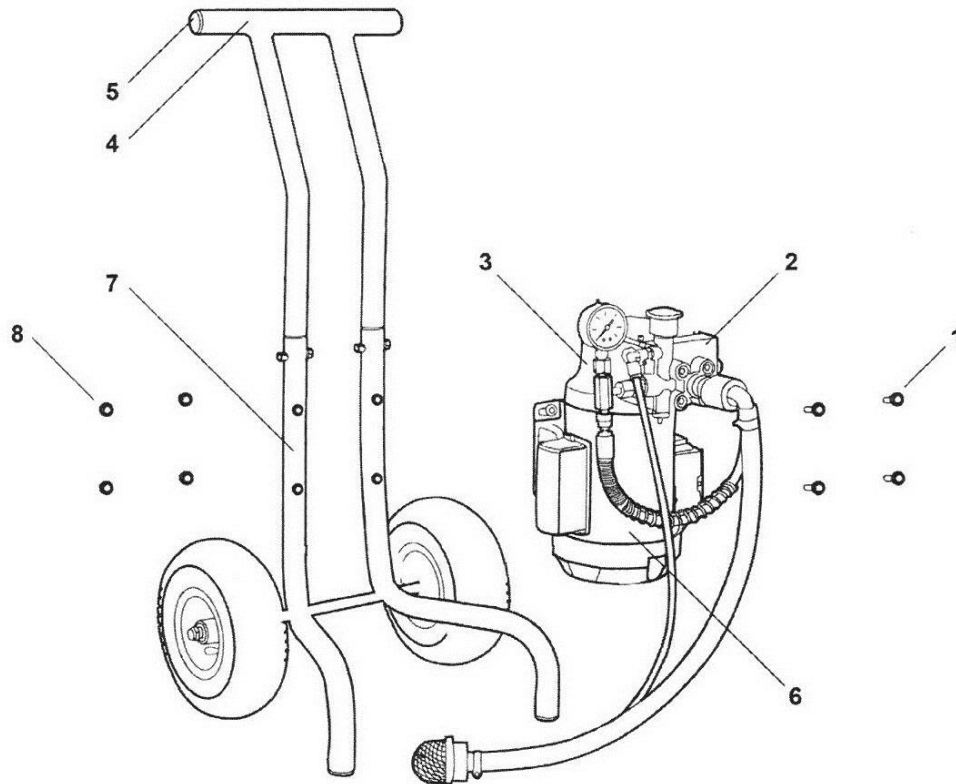

## Parts List

Item	Description	Qty	Part No.	Item	Description	Qty	Part No.
1	Bolt.....	4	AX/GM-20201	5	Plug.....	4	AX/GM-20205
2	Pump Head.....	1	AX/GM-20003	6	Motor Complete.....	1	AX/GM-20121
3	Pump Housing.....	1	AX/GM-20124	7	Frame.....	1	AX/GM-20207
4	Handle.....	1	AX/GM-20204	8	Lock Nut.....	4	AX/GM-20208

## Diaphragm Pump

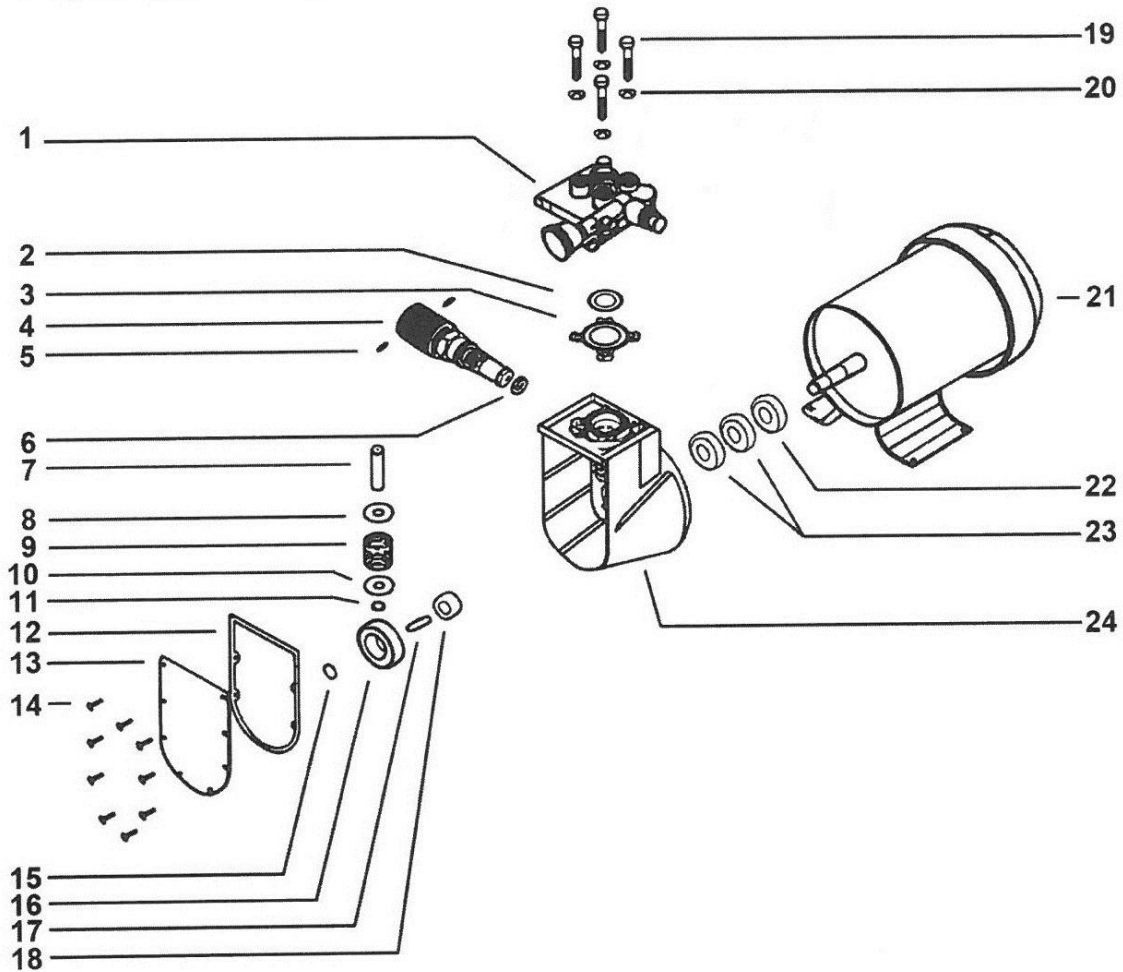

## Parts List

Item	Description	Qty	Part No.	Item	Description	Qty	Part No.
1	Pump Head.....	1	AX/GM-20003A	13	Hydraulic Cover.....	1	AX/GM-20113
2	Insert Ring.....	1	AX/GM-20102	14	Screw.....	9	AX/GM-20114
3	Diaphragm.....	1	AX/GM-20103	15	Retaining Ring.....	1	AX/GM-20115
4	Pressure Control Valve...	1	AX/GM-20104	16	Bearing.....	1	AX/GM-20116
5	Set Screw.....	2	AX/GM-20105	17	Shaft Key.....	1	AX/GM-20117
6	Seal.....	1	AX/GM-20106	18	Eccentric Sleeve.....	1	AX/GM-20118
7	Piston.....	1	AX/GM-20107	19	Head Bolt.....	4	AX/GM-20119
8	Piston Washer.....	1	AX/GM-20108	20	Washer.....	4	AX/GM-20120
9	Piston Spring.....	1	AX/GM-20109	21	Motor.....	1	AX/GM-20121
10	Piston Washer.....	1	AX/GM-20110	22	Oil Seal.....	1	AX/GM-20122
11	Retainer.....	1	AX/GM-20111	23	Bearing.....	2	AX/GM-20123
12	Gasket.....	1	AX/GM-20112	24	Pump Housing.....	1	AX/GM-20124

### Suction Assembly for Water & Enamel Base Paints

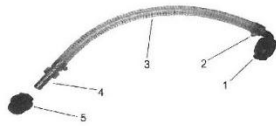

#### Parts List

Item	Description	Qty	Part No.
1	Suction Hose Connector	1	AX/GM-20301
2	Clamp.....	2	AX/GM-20302
3	Suction Hose.....	1	AX/GM-20303
4	Suction Filter Stem.....	1	AX/GM-20304
5	Suction Filter.....	1	AX/GM-20305

### Suction Assembly For Solvent Based Paints



Suction Assembly Complete

Part Number AXGM2037

### Pressure Gauge Assembly

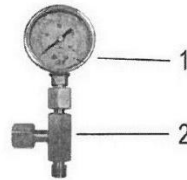

#### Parts List

Item	Description	Qty	Part No.
1	Gauge.....	1	AX/12-800-009
2	"T" Piece High Pressure...	1	AX/GM-20402

# X-360 Spray Gun

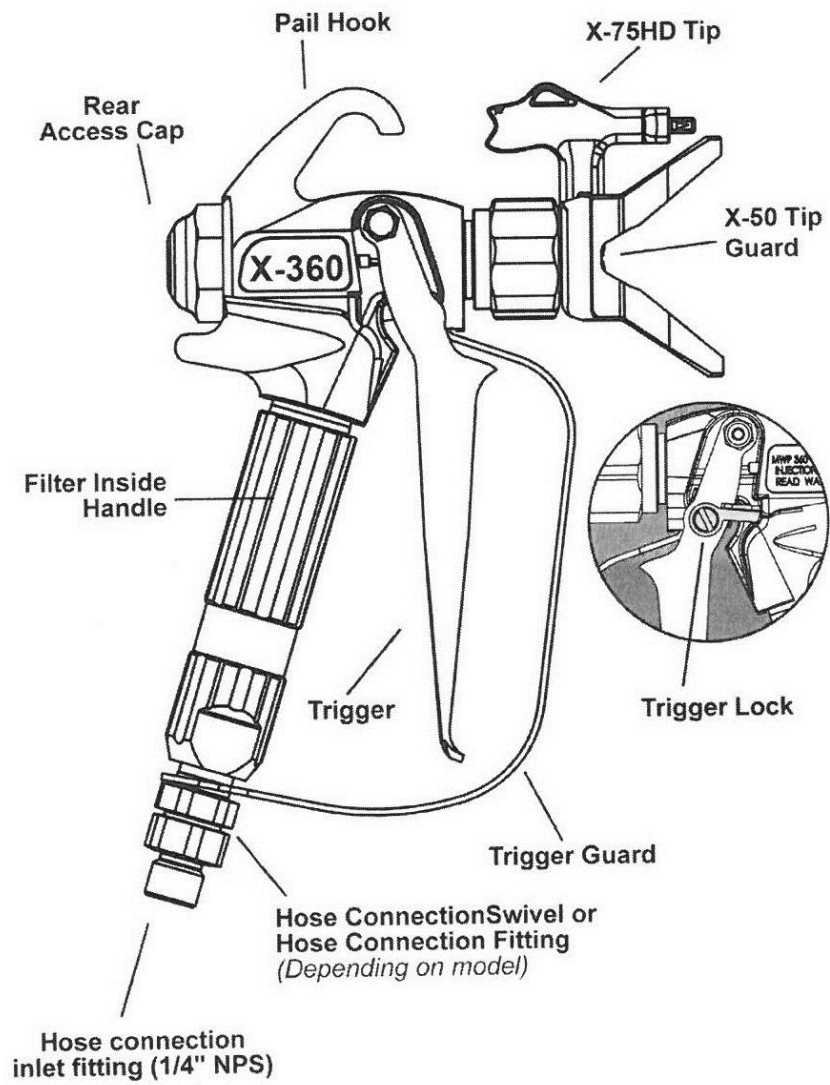

Part No. AX/02-360-000 shown in illustration above.

# X-360 Spray Gun Breakdown

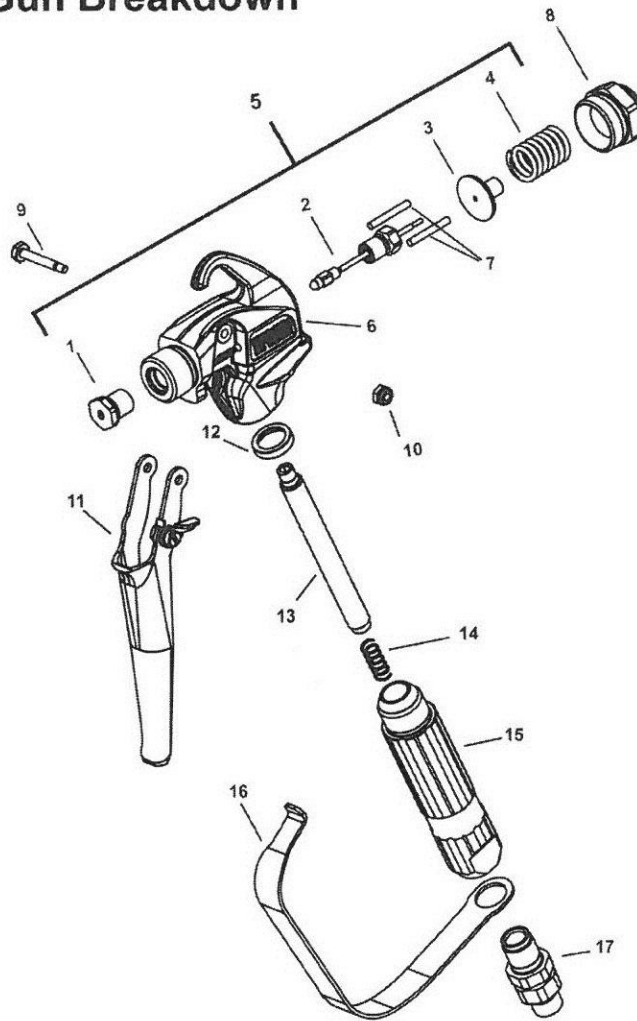

## Parts List:

Item	Part#	Description	Quantity
1	Included in #5	Diffuser	1
2	Included in #5	Valve/Seal Assy.	1
3	Included in #5	Knob, Retractor	1
4	Included in #5	Spring, Seal Assy.	1
5	AX/02-360-500	KIT, Repair - (Parts 1-4)	
6	AX/02-360-501	Head, 7/8"	1
	AX/02-360-502	Head, 11/16"	
7	AX/02-360-503	Pins, Trigger	2
8	AX/02-360-504	Cap, Rear	1
9	AX/02-360-505	Shaft, Trigger	1
10	AX/02-360-506	Nut, Trigger Shaft	1
11	AX/02-360-507	Trigger Assy., 4-Finger	1
	AX/02-360-508	Trigger Assy., 2-Finger	
12	AX/02-360-509	Seal, Handle	1
13	AX/W0034377	Filter, 50 Mesh	1
14	AX/02-360-510	Spring, Filter	1
15	AX/02-360-511	Handle	1
16	AX/01-300-000	Guard Trigger	1
17	AX/02-360-513	Swivel 1/4" Hose Connection	1

## Spray Tip and Guard Parts List



Parts List:			
Item	Part#	Description	Quantity
1	AX/01-200-XXX	X-75HD Reversible Tip	1
2	AX/01-300-000	X-50 5000psi Tip Guard 7/8"	1
	AX/01-300-001	X-50 5000psi Tip Guard 11/16"	1
3	AX/01-100-000	X Series Tip + Seal Gasket	1